



HONDA GX120 TECH MANUAL

1st Issue: February 1st,2020

Updated 1/9/2024

Technical Committee:

Kenny Brown

Jerry Mostek

Rusty Barnard

Copyrighted: POWRI QUARTER MIDGET LEAGUE

TECH SUSPENSIONS

All POWRI tech suspension must follow procedures listed in the POWRI Rule Book.

GENERAL RULES

1. Stock Honda GX120K1 engine and gearbox will be used in all 120 classes. No aftermarket blocks will be allowed. All stock parts specifically made for the Honda GX1200K1 HX2. US=GCAHK Canada =GCAAT UY-2=GCBMT. **Honda OEM 120 replacement blocks may be used. Must be an OEM Honda replacement block. No aftermarket blocks or components**
2. Stock Honda parts must be used and properly installed with the following exceptions: The following Gaskets listed below that are coming from Honda are tan & green as well as blue on both sides will be legal to use Intake Gasket, Carb Gasket, Side Cover Gasket.
2. (A) Governor system may be partially or fully removed with exception of the steel drive gear on the crankshaft. This gear must remain intact. If the shaft is removed hole must be plugged. The hole can be tapped for a thread or epoxy. NO welding.
2. (B) The Factory air cleaner must be removed. Any approved POWRI air filter may be attached to the outside of the air filter adapter. Outerwear style or equivalent can be used over carburetor only, with no adapter. Approved air filter adapters may be run with or without an air filter. Any air filter may be used with the adapter as long as there are no devices inside the air filter or adapter that will alter the airflow into the carburetor. Hose from valve cover must be attached to a catch can. The Air filter must not exceed more than a 45 degree angle and cannot point forward. Air filter cup. No additional adaptors are allowed.

The use of an air filter during qualifying at asphalt events is illegal. Tech Official has the right to allow air filters at any event if they deemed necessary.

2. (C) The Honda stock fuel tank must be removed.
2. (D) Recoil starter must be removed. Original pull cap may be cut down for washer.
2. (E) Exhaust: Stock Honda muffler must be removed. Mounting flange may be cut off of the muffler and used as an adapter flange. Any transition from "D" shape of the exhaust port to round must take place within the thickness (0.250" max.) of the flange. This applies to all exhaust systems. No steps or tapers allowed, the pipe must be 1 piece continuous pipe from flange or slip nipple to muffler coupler. No sections of pipe can be welded together (BUTT WELDED), grind marks are allowed past 0.250" flange area. No suspension for exhaust flange or pipe infraction just disqualification. If an after - market flange is used, the maximum allowed flange thickness will be 0.250" inches. If the slip-on type flange assembly is used, pipe stub will be a maximum 0.880" inches outside diameter tubing with a maximum overall length of 1.500" inches. Pipe stub must be inserted into the exhaust pipe at least 0.750" inches and will have minimal exhaust leakage. Muffler to be used will be 4 to 8 HP & Stratton, part #294599 or equal equivalent. The muffler will be internally unaltered except that the round cup shaped baffle may be welded to the perforated baffle without moving its original location. Threads will not be removed from the muffler. Exhaust pipe will be a maximum of 1.000" inches outside diameter with a length of **19.25"** to 26.0" including a threaded pipe coupler to weld to the end of the pipe in order to screw muffler in place so that the muffler may be removed for inspection. Pipe coupler will be a standard, unaltered, 3/4"NP, threaded coupler. Length will be 1.000" inches minimum to 2.250" inches maximum. There will be no steps or tapers in exhaust pipe or flange assembly. Exhaust pipe length will be measured by using a small diameter hose inserted through a pipe to measure overall length. Flange and coupler will be included in the overall length when measuring pipe. No coating of any type may be applied to the interior of any part of the exhaust system. The intent of this rule is to have all of the exhaust pass through the muffler. All measurements are to be taken with the component pieces in the same position as they were installed and on the car.

All 1/4 midget mufflers must be Briggs & Stratton PART # 294599 or equivalent. No drilling holes in the baffles. Inside seam of baffle must be straight edged. (Some seams may not be parallel in baffle) You cannot cut off the threaded flange if it is to be used in a Honda. You may weld washer or nut on the flange for the purpose of using safety wire.

- 2. (F) Choke butterfly and shaft must be removed. The hole may be filled only with silicone. Or old shaft cut down.
- 2. (G) The level switch may be disconnected, but switch assembly must remain intact in the crankcase.
- 2. (H) The gearbox may be rotated to any desired position.
- 2. (I) Main jet in the carburetor may be a maximum of #70 Max. Some jets will be silver in color are legal.
- 2. (J) Off - on ignition switch may be removed, and the hole covered (Any material: no welding).
- 2. (K) All pin measuring gauges are plus tolerance.
- 2. (L) Exhaust oxygen sensor or temp sensor attached to any part of a Honda exhaust system is illegal.
- 2. (M) Valve seals are illegal.
- 2. (N) Cryogenics of any Honda part are illegal.
- 2. (O) Note: Wear limits in engine block internal -will cover taking parts out of service.
- 2. (P) **The Honda flywheel cover shroud can be any color.**
- 2. (Q) The following infractions will be a DQ ONLY (No Suspension) for: Exhaust, Air Filter adapter, and spark plug, or valve seal, Silicone or any type of sealer or epoxy(only approved area's are choke shaft hole and governor shaft hole, multiple exhaust gaskets or more than 2 carb to insulator gaskets.
- 2. (R) A Loose jet is a 30 day suspension.

TECH PROCEDURE

No modifications or machining of any parts in order to bring them to stated minimum or maximum specs in not allowed.

External visual check of engine for required components: Pipe and muffler, shrouds and sheet metal, oil level sensor (this can be partially observed from outside).

- 1. The Factory air cleaner must be removed. Any approved POWRI air filter may be attached to the outside of the air filter adapter. Outerwear style or equivalent can be used over carburetor only, with no adapter. Approved air filter adapters may be run with or without an air filter. Any air filter may be used with the adapter as long as there are no devices inside the air filter or adapter that will alter the airflow into the carburetor. Hose from valve cover must be attached to a catch can. The air filter must not exceed more than a 45 degree angle and cannot point forward. Air filter cup. No additional adaptors are allowed.
- 2. The air cleaner adapter will be maximum ID 2.250" and a maximum of 1.375" long in length, flange thickness 0.0375" max Flange ID 1.000" minimum hole size straight walled, flat bottomed and parallel with carburetor using existing air cleaner mount holes. **Honda Gasket 16269-ZE1-800 allowed between Air Filer Cup & Carb**
- 3. The use of air filters during qualifying at asphalt events is illegal. Tech Official has the right to allow filters a at any event that it's deemed necessary.

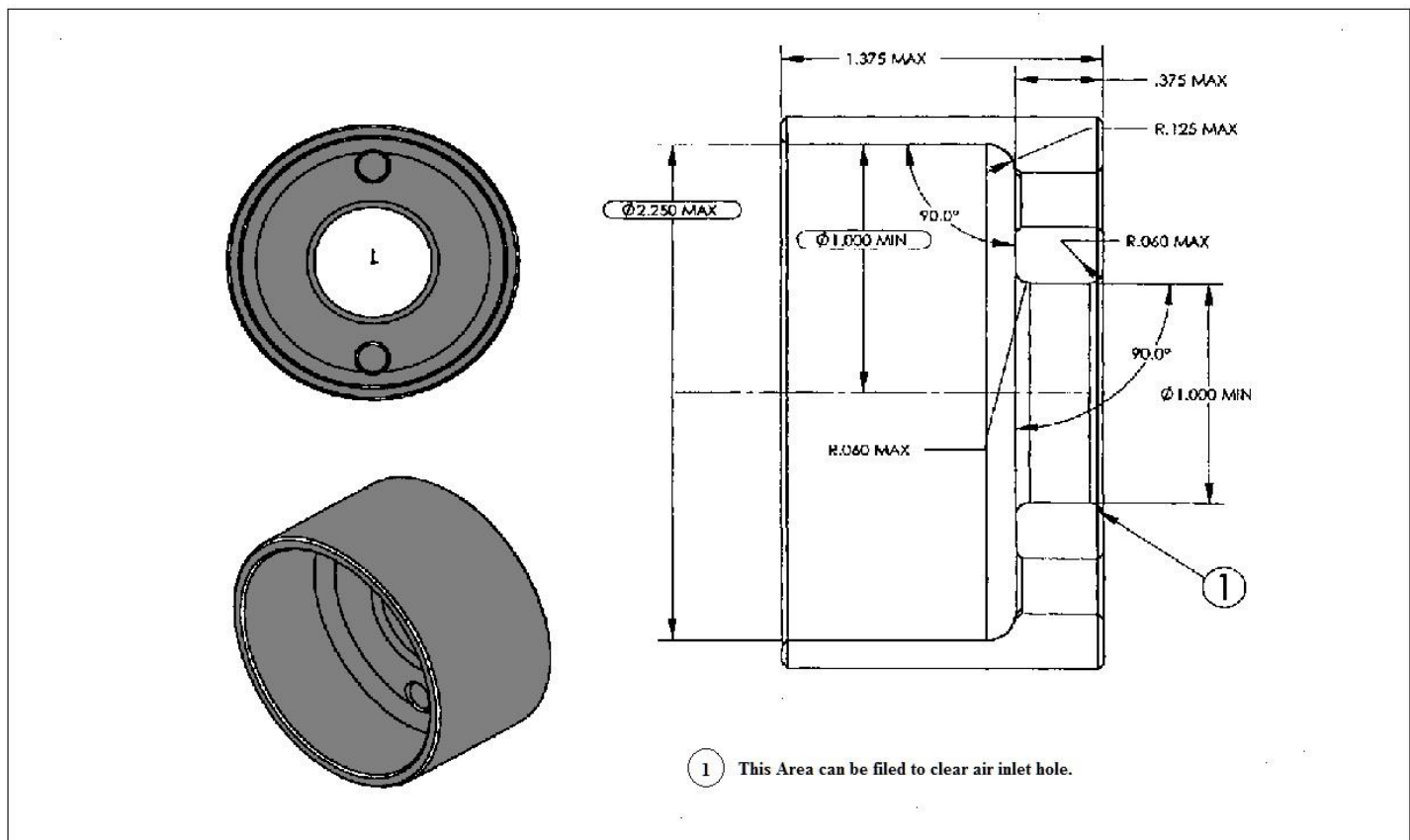

4. Any type throttle linkage may be utilized. The carburetor will be unaltered with exception of the black plastic piece on the upper end of throttle shaft, this is the only part in the carburetor that can be altered.
- A. Material may not be added to throttle stop area of the black plastic piece or carb body.
 - B. The rear mounting brackets on the Honda fuel tank may be removed.
 - C. The starter cup that is behind the flywheel retaining nut can be cut away to leave only the flat washer back piece that retains cooling fan.
 - D. The keyed end of the sun gear shaft may be shortened, drilled and tapped or machined for a snap ring.
 - E. Heli-coiling threads for shrouds (all) valve cover, existing throttle mounting holes, oil drain, and fill holes, one of the coil bolts, and side cover bolts, One carburetor mounting bolt is allowed. Dowel holes are not to be modified or relocated
 - F. Honing and deglazing of the bore is allowed.
 - G. Lapping the valves is allowed
 - H. Blocking Air Flow: No device may be used that will/or appear that it may impede airflow into the engine cooling system. This may require that the engine be run at a speed above idle by the tech personnel at the scale after the car has qualified or raced.

CARBURETOR

GX160 CARBURETOR MAY BE USED IN HEAVY HONDA ONLY (See GX160 Manual for carb specs)

Removal of Carburetor

1. Check for restrictor, if applicable, and placement. Restrictor must be installed between the carburetor and carburetor insulator with a stock Honda gasket on each side or restrictor. Only stock Honda insulator gasket between black insulator and head is permitted. Air passageway in insulator will not be altered in any way. All Junior Honda's must use blue POWRI, QMA, or USAC approved slotted plate

only. All Junior plates must be dated 06-09 or newer. Failure to use a proper restrictor plate, alteration of restrictor plate, or improper installation of plate in designated class is cause for immediate DQ and all applicable suspensions will be applied.



- A. Either Japanese or Thailand insulator may be used.
 - B. Gasket thickness: 0.025" maximum
 - C. Restrictor thickness: 0.0625" maximum (No slotting of holes in any Honda plate)
 - D. Insulator Gasket thickness: 0.025" maximum
 - E. Novice restrictor hole size: 0.3125" maximum (red). The plate must have POWRI Logo.
 - F. Junior restrictor hole size: 0.4375" maximum (blue). Note: Blue plate only must be dated 06-09 or newer. (DQ and 30 day suspension if found that plate has been tampered with),
 - G. Restrictors will be teched by NO-GO gauge or caliper.
2. Check for any alterations or worn parts that would allow additional air into the engine: holes, slots, perforations, spacers, loose bolts, warped flanges, etc.
 3. Carburetor identification numbers Jr. & Sr. Honda: BE60B, BE60R, UT2 carb BE99A
 4. Carburetor identification numbers Heavy Honda: BE65B, BE65Q AND BE54D. (See spec in 160 manual)
 5. Check carburetor for alterations: Upper choke shaft hole may be sealed with silicone type sealer.
 6. Two stock Honda intake gaskets may be used between the carburetor and plastic insulator.
 7. Honda gasket #16269-ZE1-800 will be allowed between air filter cup and carburetor.
 8. Carburetor Bore:
 - Intake End: maximum diameter 0.951"
 - Throttle End: maximum diameter 0.632
 9. Carburetor Venturi bore: 0.456" NO-GO. This measurement is best made with a no go gauge, but may be made using telescoping gauge as a no go.

Pilot Air Jet hole location:
Just inside of brass piece.
Needs checked with proper
pin type no-go gauge.

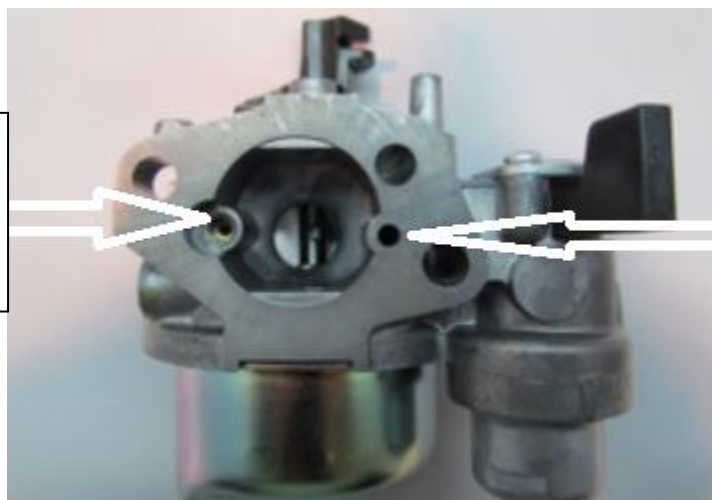

Main Air Jet hole location:
Needs checked with proper
pin type no-go gauge

10. Main jet and main nozzle (MUST BE TIGHT)

Main Jet Size: maximum #70 (0.028) no go. Jets must be stock, unaltered, no stepping or funneling of jet.

A. Main Air Jet: 0.0394" maximum #60 (0.040") no go - at the back of bore.

B. Main Jet access passage: 0.094" maximum #41 (0.096") no go.

Main Nozzle:

A. Main nozzle bore: 0.070" maximum #50 (0.070") no go.

B. Main nozzle will be checked with no go gauge (0.429"). If the gauge goes over dump tube- carb is illegal. This is best measured using a 0.452" rod type gauge with a 0.429" flat area to be used as a go gauge.

C. Air vent holes on the side of the main nozzle must not be plugged.

D. Main nozzle must not be fastened into the carburetor body by anything other than main jet. It must not be epoxied or positioned any other means.

11. Slow Speed System

A. Pilot jet: 0.0138" maximum #79 (0.0145") no go.

B. Pilot air jet: 0.050" minimum 1.25mm (0.0492") go.

C. Pilot screw: no spec

D. Pilot seat diameter: 0.035" maximum #61 (0.039") no go.

E. Tip of pilot screw 0.019" minimum.

12. Float Bowl Vent: 0.118 maximum #31 (0.120") no go.

13. Needle Valve Seat: 0.065" maximum #51 (0.067") no go.



GX 120 Dump Tube

Must be a stock Honda GX 120 Dump Tube. NO ALTERATIONS OF ANY KIND

14. The butterfly screw, the butterfly, and the throttle shaft must not be removed from the carburetor. Any evidence of tampering will be a disqualification and suspension.
15. Decimal equivalents of numbered size drills. See chart in the back of this book.

ENGINE COOLING SHROUDS

1. All pieces of the stock engine-cooling shrouds must be properly installed.
2. There must be no addition or subtraction of any material from the shrouding except for the covering of the switch hole (any material). Starter cup may be altered to be used as a washer retainer for the cooling fan.
3. Shroud must be red or black. NO OTHER COLORS ALLOWED.
 - A. Remove engine - cooling shroud. Remove valve cover.
 - B. Zero dial indicator after exhaust bump (0.050") ref.
 - C. The maximum valve lift will be checked from the top of the valve spring retainer. Valves may be adjusted to zero clearance. This may dictate making special shims, as it is different to insert feeler gauge blades so as not interfere with indicator contacts on retainer.

Valve Lift:

| | |
|-----------|----------------|
| Intake: | 0.245" maximum |
| Exhaust:: | 0.255" maximum |



CYLINDER HEAD, HEAD GASKET, VALVES SPRINGS

Remove Cylinder head

Head gasket thickness: 0.040" minimum thickness of inner rim.

Measure from head surface to top of the valve head:

Intake: maximum 0.210" minimum 0.178"

Exhaust: maximum 0.210" minimum 0.178"

This is best done with a depth micrometer or bridge type dial indicator. Bridge type does not require removing carbon from head surface.

Combustion chamber cc: 10cc ref. with stock spark plug.



Remove valves:

Retainer:

1. Inspect retainers for alteration that would increase valve spring pressure. Both intake and exhaust must have stock Honda retainers. Exhaust valve only can have lash cap and corresponding retainer.
2. Thickness of the retainer will be:
Intake: 0.228" minimum
Exhaust: 0.241" minimum
3. Flange thickness of the retainer will be:
Intake: 0.110" maximum
Exhaust: 0.070" maximum
4. From flat of flange to machined surface:
Intake: 0.148" minimum
Exhaust: 0.165" minimum
5. All valve oil seals be removed:
The use of valve seals is illegal will be a DQ only no suspension.

VALVE SPRINGS

Valve springs will be stock Honda springs and will not be altered in any way.

120 VALVE SPRINGS

1. Wire diameter: 0.071" maximum
2. Outside diameter of spring: 0.790" maximum
3. Number of total coils: 5.3
4. Spring pressure: 11LBS maximum at 0.812"
5. Stacked length will be: 0.394" maximum

140 VALVE SPRINGS

1. Wire diameter: 0.079" maximum
2. Outside diameter of spring: 0.816" maximum
3. Number of total coils: 7
4. Spring pressure: 16lbs. maximum at 0.812"
5. Stacked length will be: 0.524" maximum



ROCKER ARMS- PUSH RODS-STUDS

Rocker arms will be stock Honda and will not be altered in any way. Rocker arm studs will be stock Honda. They or their mounting position may not be altered in any manner. No heli-coiling of mounting holes. No bending of studs. Push rods will be stock Honda and will not be altered in any way. Push rod length will be maximum 4.803"

VALVES

1. Check valves for dimensions and weight. Valve seating surface must be factory ground to a single angle only, 45 degrees. There will be no other angles ground any part of a valve. Valves must not be polished, lightened or altered in any way.
2. Valve weight:
Intake: 18 grams minimum Exhaust: 16 grams minimum
3. The drawings shown below of valve dimensions (Intake Valve followed by Exhaust Valve)

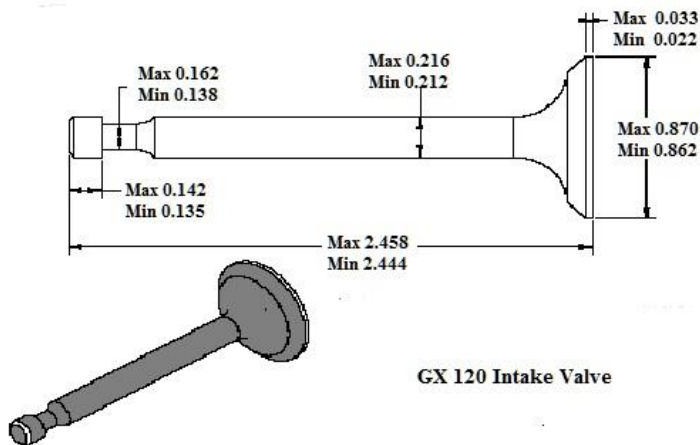

GX 120 Intake Valve

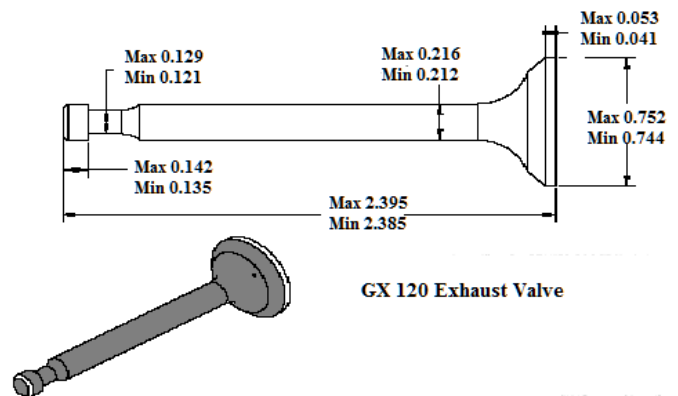

GX 120 Exhaust Valve

No Mixing of old and new style parts are allowed- UT1 (Current 120) exhaust valve part #14721-ZF0-000 Retainer # 14781-ZE1-000 must be used in combination. UT-2 (New 120) exhaust valve part #14721-Z4H-000 and-Retainer #14771-ZE1-000 must be used in combination. New style exhaust valve Part # 14721-Z4H-000 measures 2.470 overall length.

Head

The cylinder head will be in "as cast" and in factory machined condition and there must be no addition of metal or and other substance to the inside or outside of the cylinder head. No alteration that could increase valve spring pressure. The cylinder head gasket surface is non tech. Only Thailand Head allowed is the TKI9 with the Honda Performance Development logo. Any legal Japanese R/K GX120 head may be used. Latest GX 120 head B100 and BOO. Will also be marked Honda Performance Development logo.

No cleaning of the combustion chamber or changing the finish of such chamber is illegal.

GX 120 RK HEAD

1. Measure from flat of head surface down to valve seat. This dimension will be:
 - A. Latest head cylinder #12210-ZH7-415
Maximum 0.265" Minimum 0.250
 - B. Measure from surface of head to top of the valve guide.
This dimension will be 0.925 Max
Intake 0.925 Max
Exhaust 0.925 Max

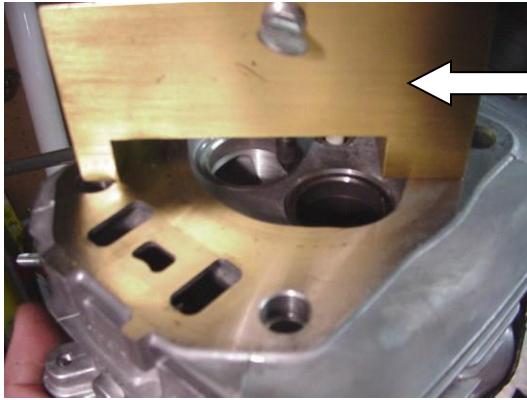

R/K



C. Measure from surface of head to lowest machined area in the bowl of the port.

This dimension will be:

| | |
|---------|----------------|
| Intake | 1.064" maximum |
| Exhaust | 1.010" maximum |

D. Thickness of head. This will be measured from valve cover surface to head gasket surface at the side at a position in line with upper intake & exhaust flange bolt.

| | |
|---------|--------|
| Maximum | 2.917" |
| Minimum | 2.911" |

Note: Most heads in field have a thickness of 2.914

TKI9 HEAD

A. Measure from flat of head surface down to valve seat

This dimension will be:

| | |
|---------|----------------|
| Intake | 0.235" minimum |
| Exhaust | 0.250" maximum |

B. Measure from surface of head to top of valve guide

This dimension will be

| | |
|---------|----------------|
| Intake | 0.925" maximum |
| Exhaust | 0.925" maximum |

C. Measure from surface of head to the lowest machined area in the bowl of port.

This dimension will be

| | |
|---------|----------------|
| Intake | 0.164" maximum |
| Exhaust | 0.955" maximum |

D. Thickness of head. This will be measured from valve cover surface to head gasket surface at the side at a position in line with upper intake & exhaust flange

| | |
|---------|--------|
| Minimum | 2.900" |
|---------|--------|

INTAKE AND EXHAUST PORTS

1. Ports will be "as cast" and in factory machined condition and there must be no addition or subtraction of metal or any other substance to the inside or outside of the cylinder head.
2. No alterations of any kind to be made to the intake or exhaust port.
3. This includes any grinding, polishing, etching, sandblasting or glass beading to interior surface.
4. Valve seats must be stock single 45 degree angle. Multi angle valve seats are not permitted. Valve seats must not be replaced.
5. Intake and Exhaust ports at valve

| | | | | |
|----------|---------|--------|---------|--------|
| Intake: | maximum | 0.752" | minimum | 0.745" |
| Exhaust: | maximum | 0.675" | minimum | 0.665" |

Use of 5/16 studs is allowed to repair the factory exhaust studs. No altering of hole location.

ENGINE BLOCK

This engine block must be "as cast" and in factory machined condition. There must be no addition or subtraction of metal or any other substance to the inside or outside of cylinder block, crankcase cover, crankshaft, rod, piston, pin, rings, flywheel or coil with the following exceptions:

1. Removal of rear gas tank brackets is permitted.
2. Removal of governor. Governor system may be partially removed with the exception of the steel gear on the crankshaft. This gear must remain intact. Governor arm and shaft may be removed, tied forward or altered to accommodate the throttle linkage or return spring.
3. It is permissible to use loctite on all Hondas engine side cover bolts.
4. Addition of brackets, fittings etc. to accommodate the throttle linkage, tachometer, temperature gauge is allowed.
5. The cylinder block deck surface is non tech.

Check Bore: 2.366" maximum Please note : **All measurements taken at top of bore or very bottom of bore.**
"Wear limits/parts out of service" POWRI has the right to confiscate any 120 Honda engine parts deemed illegal or at POWRI maximum wear limits. Example: Cylinder bore will be 2.366" Max. All measurements was taken at top of bore or very bottom of bore parallel to crank,90 degrees from crank. Any cylinder block that has one measurement over POWRI maximum wear limits will be taken out of service. If no measurements exceed maximum wear limits the part of block will not be confiscated. The handler has the right to have the confiscated parts returned to them but it will be rendered unusable.

Use a dial caliper to check bore.

Check Stroke: 1.659" maximum 1.640 minimum

Measurer amount that piston is up or down from block surface at T.D.C. This will be measured at the edge or highest part of piston, not in center or relieved area.

This dimension will be: 0.000" Max - No piston pop up

Install degree wheel on the flywheel. Install the pointer in order to read degrees. Locate accurate T.D.C. This should be done with a position stop type fixture and not established with indicator alone.

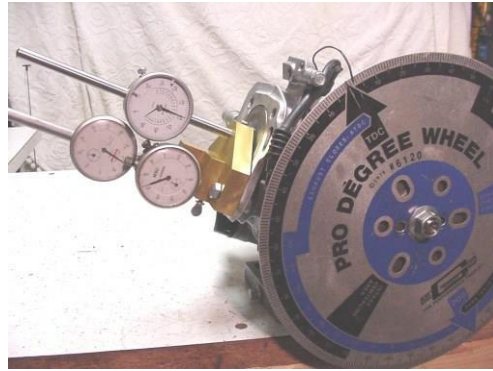

Cam will be checked with indicator reading off the top end of tappets, which will provide zero clearance. The inverted radius of the top of the tappet presents some problem to get an accurate reading and to prevent binding of zero indicator on the base circle of the cam. Be sure that compression release does not affect zeroing exhaust indicator. (Zero dial indicator after exhaust bump) Ref

Turning engine in normal rotation, clockwise facing flywheel, take reading at specified opening. Reading must fall between specified degrees on the following chart.

CAMSHAFT PROFILE LIMITS

| Intake Degree | Exhaust Degree |
|---------------------------------|---------------------------------------|
| 0.050" 10.5 -14.5 ATDC | 0.050" 206 - 210.5 BTDC |
| 0.100" 26.5 -30.5 ATDC | 0.100" 189 - 193.5 BTDC |
| 0.150" 45 - 49.5 ATDC | 0.150" 170 - 174.5 BTDC |
| 0.180" (SPLIT) | 0.180" (SPLIT) |
| 0.200" 71 - 76 ATDC | 0.200" 144 - 148 BTDC |
| MAX LIFT | MAX LIFT |
| 0.227" Peak 104-107 ATDC | 0.229" Peak 107.5 - 110.5 BTDC |
| 0.200" 135 - 141 ATDC | 0.200" 69.5 - 74.5 BTDC |
| 0.180" (SPLIT) | 0.180" (SPLIT) |
| 0.150" 162 - 167 ATDC | 0.150" 43 - 48.5 BTDC |
| 0.100" 180 - 185 ATDC | 0.100" 24.5 - 29.5 BTDC |
| 0.050" 197 - 201 ATDC | 0.050" 8.5 - 12.5 BTDC |

FLYWHEEL, FAN AND IGNITION SYSTEM

Caution should be used when removing flywheel. Do not hit with hammer or other heavy objects. Service manual show flywheel to be removed with commercially available 6" puller. Another method is an inertia type knocker that threads onto crankshaft end.

The transistorized magneto ignition is fixed at 20 degrees BTDC and may not be altered in any way. Firing must not exceed 0.0665" or 20 degrees BTDC. Quick check: Turning flywheel clockwise-if the leading edge of the depression of the flywheel rim where the magnet is mounted is not still under the right hand coil leg at

0.065" BTDC, it is probably illegal and should be checked further. If timing needs to be checked further see page 21.



1. Flywheel keyway or its position must not be altered. White magnet flywheel and stock or offset key is DQ and 30 day suspension.
2. Any key may be used but not to exceed 20 degrees of timing.
3. Magnet and its position may not be altered in any way.
4. The magnet retaining screw may not be altered in any way. The screw may not be replaced with larger or smaller screw. No heli-coiling of mounting hole.

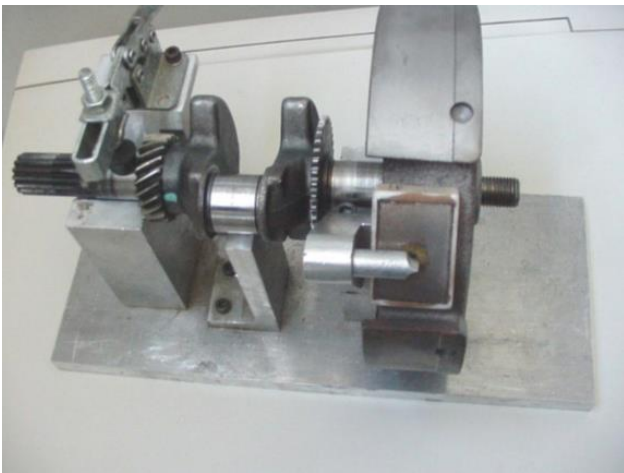

5. Ignition coil or its position, other than air gap, may not be altered in any way. Coil mounting bolts must be stock and cannot be altered in any way to advance or retard timing. Coil attaching bolts will be stock 6mm cap screw 1-1/16" long. There can be no more than 3/8" of the unthreaded portion of bolt that does not measure 0.230" diameter. This restricts movement of the coil to a position that could make ignition timing illegal. If a coil support mount becomes stripped, it is permissible to Heli-coil. However, only one leg may be repaired, if both legs are Heli-coiled, the block becomes illegal.

6. All nylon blades on the cooling fan.



7. No metal removal or addition to the flywheel is permitted.
Flywheel weight will be: 1550 grams minimum
Flywheel diameter - magnet area: 6.285" minimum
8. A stock Honda spark plug cap, (wire end and resistor), must be used.
9. Any automotive type spark plug with 3/4" reach maximum is allowed. Note Tapered seat spark plugs are illegal . Race DQ only.
10. The ignition coil air gap is a maximum of 0.035"
11. No plug-indexing washers allowed.
12. If temperature sensor is used under spark plug, factory washer may be removed.

GEAR BOX AND RING GEAR

1. Gear box may not be altered in any way. May be rotated to desired position.
2. Ring gear may not be altered in any way with the exception of the keyed end of the shaft that may be shortened, drilled and tapped or machined for the snap ring groove. No other machining, drilling grinding, etc. to ring gear. Keyway may be cut deeper.
3. Ring gear may not be altered in any way, including polishing or use of any compound or abrasive on gear shaft where the bearings ride.
4. Two gaskets maximum between gear box halves.
5. Loctite is permissible to be used on gear box to side cover bolts.



CRANKCASE COVER

Remove crankcase cover.

1. The cover must be "as cast" and in factory machined condition and there must be no addition or subtraction of metal or any other substance to crankcase cover.
2. The crankcase cover gasket must be stock Honda. Only one gasket may be installed with a maximum thickness of 0.025".
3. Critical dimensions are - thrust face of camshaft holder and position of crank bearing. Place a straight edge over crank bearing and cam boss thrust face. These surfaces should be level. Maximum tolerance will be + 0.005". There will be no alterations to crankcase cover. This includes any alteration to crank bearing and camshaft holder position and height in an attempt to alter valve timing.

PISTON - WRIST PIN AND PISTON RINGS

Remove the rod and the piston - triangle or boss on top of the piston must point toward push rods - piston, wrist pin and rings must be absolutely stock and not altered in any manner.



PISTON

The piston will be stock Honda standard size and will not be altered in any way.

1. Oversized pistons must not be used.
2. All three piston rings must be used and installed properly.
 2. (A) Top ring: Chrome compression ring installed with "N" or "T" on rail up. Thai rings are marked R. No expander under ring.
 2. (B) Middle ring: Oil scraper ring installed with "N" or "T" on rail up. Thai rings are marked R. No expander under ring.
 2. (C) Bottom ring: Three (3) piece oil rings are allowed. Check oil ring expander for alterations that will alter ring tension (cutting ends of expander ect.)
3. Piston may not be knurled, grooved or coated.
4. Piston weight: 106 grams minimum.
5. Total Piston weight: With rings, pin, and clips 121 grams minimum.
6. Total Piston weight with rings, retainers, complete with rod, pins and bolts 263 grams minimum.
7. See dimensions below.

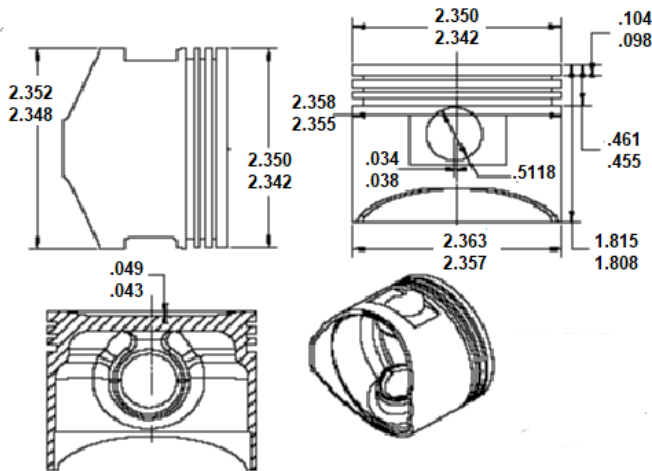

TIER III PISTON

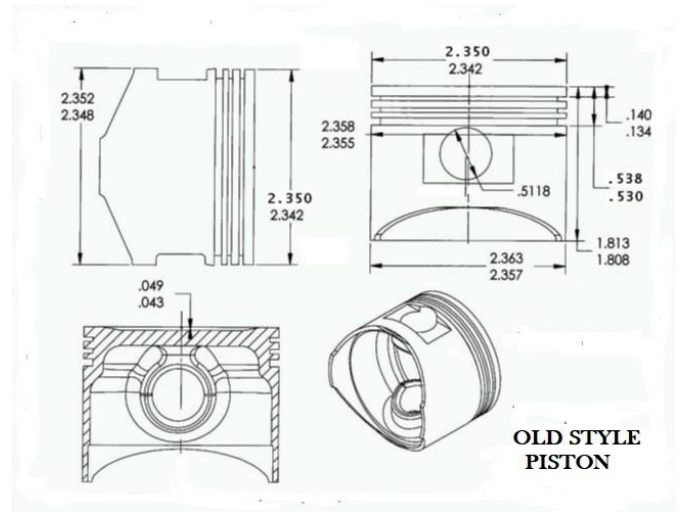

OLD STYLE PISTON

RINGS

1. Must be stock Honda rings with stock size and configuration. Compression and scraper rings may not be collapsed in the groove.
2. No decreasing of ring tension by heating, machining or any other means.
3. Ring thickness:

OLD STYLE:
 Compression: 0.056" min.
 Scraper : 0.056" min.

TIER III:
 Compression: 0.036" min.
 Scraper: 0.036" min.

Oil Ring: 3 piece lower 0.095" min. 1 piece 0.097" min.

WRIST PIN

Stock Honda wrist pin and retainer

OD: 0.511 ref. +/-

Length: 1.864" + 0.010"

ID: 0.354"

Weight: 23 grams minimum



CONNECTING ROD

Stock Honda rod with no alterations.

1. Connecting rod big end size: 1.021" minimum - 1.0265" maximum
2. Pin end bore is 0.5111 ref.
3. Length from bottom of pin bore to top of big end bore will be:
2.111" maximum 2.101" minimum
4. Rod weight with bolts: 119 grams or 4.2 oz minimum
5. No oil grooves on bearing surface of either end.
6. Thai rods may have light sanding marks.

CRANKSHAFT

Stock Honda crankshaft with no alterations.

1. No removal or addition of any metal from or to the crankshaft is allowed.
2. No balancing of the crank is allowed.
3. No oil grooving is allowed on the crank journal.
4. Governor drive gear cannot be removed.
5. Crankshaft drive gear should not be removed. This gear is installed by Honda to any accuracy of + 1/2 degree. If this gear is not installed to this degree of accuracy, the engine may not be legal when camshaft is checked by the procedure under engine block.
6. Keyway location must not be altered in any manner.
7. Measure thrust to crank gear side: 3.340 Min.
8. The only cleaning method allowed is on the flywheel side of crankshaft for the purpose of removing calcium, rust etc. from the exposed end of the crankshaft. This is permitted only from the seal groove out to the end of the thread of the crankshaft where the flywheel bolts on. Only a wire wheel may be used in the cleaning process. The use of Scotchbrite, sandpaper or any other compounds or abrasives is illegal. No material may be added or removed from the crankshaft. Crankshaft main journal at the flywheel and gearbox ends may not be altered in any way. Heat treat rings on splined end of crank is no longer a tech item as long as crank still makes spec. And has not been modified.



CAMSHAFT

The camshaft must be stock Honda with no alteration of any kind.

1. There will be no additions to or subtractions from any part of the camshaft.
2. Compression release will remain intact and unaltered.



3. The lobe center angle will not be altered by any means.
4. The lobe profile will not be altered in any way.

CAMSHAFT SPECIFICATIONS

INTAKE

Heel to Heel 0.864" - 0.869"

Heel to Heel 0.865" - 0.870"

EXHAUST

Heel to Peak 1.079" - 1.093"

Heel to Peak 1.081" - 1.095"

Length - thrust flange to thrust flange: 3.135" minimum 3.142" maximum

TAPPETS

1. Tappets must be stock Honda with no alterations.
2. Base diameter: 0.909" minimum no maximum spec
3. Stem diameter: 0.312 minimum
4. Base thickness: 0.076" minimum 0.090" maximum
5. Length: 1.220" maximum
6. Weight: 16 grams minimum

ENGINE BLOCK INTERNAL

The engine block must be in an "as cast" and factory machined condition and there must be no addition or subtraction of metal or any other substance to the inside or outside of the block.

1. Cylinder bore will be 2.366" maximum. NOTE: All measurements taken at top of bore or very bottom of bore.
 - 1.(A) "Wear Limits/Parts Out Of Service" POWRI reserves the right to confiscate 120 Honda engine parts deemed illegal or at maximum wear limits. EXAMPLE: Cylinder Bore will be 2.366 Max. All measurements taken at top of bore or very bottom of bore parallel to crank, 90 degrees from crank. Any cylinder block that has one measurement over maximum wear limits will be taken out of service. If no measurements exceed maximum wear limits the part of block will not be confiscated. The handler has the right to have confiscated parts returned to them but will be rendered unusable.
2. Cylinder bore will not be bored oversize.
3. Cylinder bore will not be re-sleeved.
4. Cylinder bore position will not be moved or tipped in any manner.
5. Cylinder block deck surface finish non tech.
6. Machined surface of block down to thrust face of cam boss:
3.228" minimum 3.240" maximum
7. Machined surface of block down to bearing face:
3.430" minimum 3.442" maximum
8. Oil level sensor will be intact and unaltered. Wires may be externally disconnected or cut off.

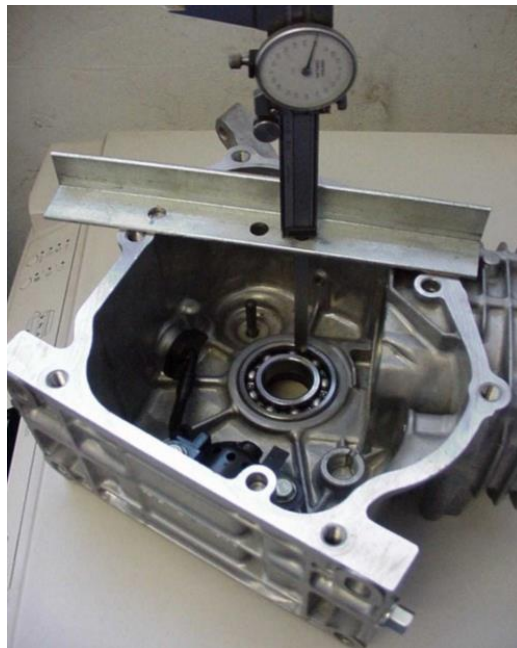

PROCEDURE FOR CHECKING TIMING

1. With degree wheel or indicator located at 0 degrees or TDC., mark both the flywheel and some fixed point (such as right hand side of aluminum block casting right above flywheel) with aligning marks. Turn the flywheel clockwise and stop at 20 degrees BTDC or 0.065" – 0.066." BTDC on your indicator. Make another mark on the block casting that aligns with your mark on the flywheel.
2. Remove dial indicator so it will not be damaged by engine rotation.
3. Install timing light to a battery, if not self powered, and clamp inductive pickup to spark plug wire. Wire should be hooked to standard spark plug gapped to 0.025". Using a drill, with an extension that is cut off or turned to fit drill, place socket on flywheel nut and rotate the engine in clockwise direction.
4. Fire the timing light and observe. If the reference mark on the flywheel is between the two marks on block casting that are TDC and 0.066" or 20 degrees BTDC **max @1200 RPM +/- 50 RPM**, the timing is legal. If the mark is not between marks on block casting when rotating, the engine will be disqualified.
5. Other pictures and text indicate methods of detecting which particular part is not in spec.

Tech officials have the right to tech any or all cars in any class at their discretion. Tech Officials can tech at any event in POWRI. The POWRI Tech Committee is the final authority on all tech issues.

| DECIMAL EQUIVALENTS OF NUMBER SIZE DRILLS | | | | | | | |
|--|-----------------|------------|-----------------|------------|-----------------|------------|-----------------|
| No. | Size in | No. | Size in | No. | Size in | No. | Size in |
| | Decimals | | Decimals | | Decimals | | Decimals |
| 1 | .2280 | 21 | .1590 | 41 | .0960 | 61 | .0390 |
| 2 | .2210 | 22 | .1570 | 42 | .0935 | 62 | .0380 |
| 3 | .2130 | 23 | .1540 | 43 | .0890 | 63 | .0370 |
| 4 | .2090 | 24 | .1520 | 44 | .0860 | 64 | .0360 |
| 5 | .2055 | 25 | .1495 | 45 | .0820 | 65 | .0350 |
| 6 | .2040 | 26 | .1470 | 46 | .0810 | 66 | .0330 |
| 7 | .2010 | 27 | .1440 | 47 | .0785 | 67 | .0320 |
| 8 | .1990 | 28 | .1405 | 48 | .0760 | 68 | .0310 |
| 9 | .1960 | 29 | .1360 | 49 | .0730 | 69 | .0292 |
| 10 | .1935 | 30 | .1285 | 50 | .0700 | 70 | .0280 |
| 11 | .1910 | 31 | .1200 | 51 | .0670 | 71 | .0260 |
| 12 | .1890 | 32 | .1160 | 52 | .0635 | 72 | .0250 |
| 13 | .1850 | 33 | .1130 | 53 | .0595 | 73 | .0240 |
| 14 | .1820 | 34 | .1110 | 54 | .0550 | 74 | .0225 |
| 15 | .1800 | 35 | .1100 | 55 | .0520 | 75 | .0210 |
| 16 | .1770 | 36 | .1065 | 56 | .0465 | 76 | .0200 |
| 17 | .1730 | 37 | .1040 | 57 | .0430 | 77 | .0180 |
| 18 | .1695 | 38 | .1015 | 58 | .0420 | 78 | .0160 |
| 19 | .1660 | 39 | .0995 | 59 | .0410 | 79 | .0145 |
| 20 | .1610 | 40 | 0.098 | 60 | .0400 | 80 | .0135 |

Please see the Addendum for the new TIER 3 GX 120